



### Packaging Inspection Check-Off Form

Name(s): \_\_\_\_\_  
Date box was packaged, inspected, weighed & verified to insure all parts were inside & correct: \_\_\_\_\_

### 10" Radius Arm Lift Kit (2019-2022 Ram 2500)

- Front Track Bar Bracket **BOX 1**
- Front Track Bar Alignment Cams & Washer
- Front Radius Arm Drop Brackets
- Billet Face Plates For Radius Arm Drop Brackets
- Radius Arm Drop Bracket Insert Sleeves
- Front & Rear Brake Line Brackets
- Rear Driveline Spacer
- Transfer Case Re-Clocking Ring
- Re-Clocking Billet Adaptor
- Re-Clocking Seal
- Re-Clocking Hardware
- Drop Pitman Arm
- Rear 4-Link Drop Bracket Shims
- Rear Boxed Track Bar Bracket Brace Billet Spacer
- Front Sway Bar End Link Brackets

- Rear Track Bar Bracket **BOX 3**
- Rear Track Bar Bracket Brace
- Boxed Rear Track Bar Bracket Brace
- Rear Coil Springs
- Rear Coil Spacers
- Hardware Pack
- Transmission Crossmember

- Front Coil Springs **BOX 4**
- Front Bump Stop Drop Brackets
- Front Sway Bar End Links
- Bushings & Sleeves For Front Sway Bar End Links
- Rear Sway Bar End Links
- Bushings & Sleeves For Rear Sway Bar End Links
- Rear Bump Stop Drop Brackets
- Rear 4-Link Drop Brackets
- Rear 4-Link Drop Bracket Sleeve Inserts
- Rear Lower Link Reinforcement Arms
- 
- Front Coil Retainer Kit

- Front Radius Arms **BOX 2**
- Radius Arm Bushings

# #54418 10" LIFT KIT (RADIUS) 2019-22 DODGE RAM 2500

559-226-8196  
4603 E. VINE AVE  
FRESNO, CA 93725  
www.mcgaughys.com

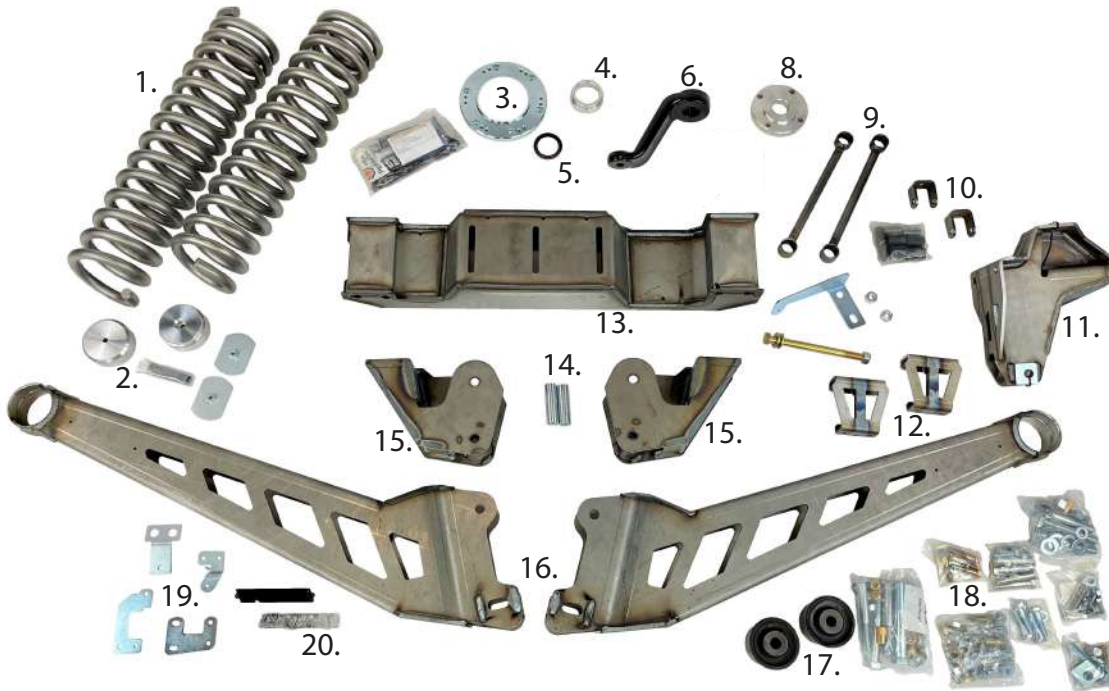

1. Front Lift Coils
2. Front Coil Retainer Kit
3. ReClocking Ring
4. ReClocking Seal Adaptor
5. ReClocking Seal
6. Drop Pitman Arm

8. Rear Drive Line Spacer
9. Front Sway Bar End Links
10. Front Sway Bar End Link Brackets
11. Front Track Bar Drop Bracket
12. Front Bump Stop Drop Brackets
13. Transmission Crossmember
14. Front Radius Arm Drop Bracket Spacers
15. Front Radius Arm Drop Down Brackets
16. Front Radius Arms
17. Front Radius Arm Bushings
18. Hardware Packs
19. Front And Rear Brake Line Brackets
20. Name Badges for Radius Arms
21. Rear 4-Link Drop Reinforcement Brackets
22. Rear 4-Link Drop Down Brackets

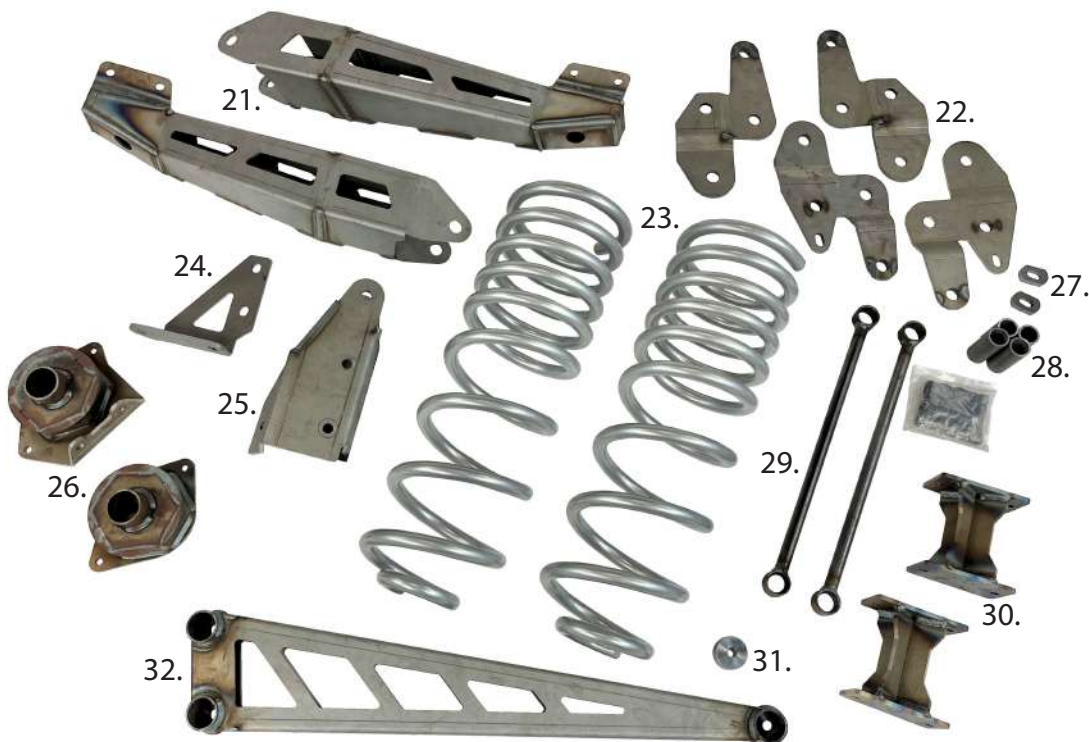

23. Rear Lift Coils
24. Rear Track Bar Reinforcement Bracket
25. Rear Track Bar Extension Bracket
26. Rear Coil Spacers
27. Rear 4-Link Drop Bracket Shims

28. Rear 4-Link Drop Bracket Spacer Sleeves
29. Rear Sway Bar End Links
30. Rear Bump Stop Drop Down Brackets
31. Spacer Puck for Rear Track Bar Reinforcement Axle Bracket
32. Rear Track Bar Reinforcement Axle Bracket



**McGAUGHYS**  
S U S P E N S I O N P A R T S

559-226-8196  
4603 E. VINE AVE.  
FRESNO, CA 93725  
[www.mcgaughys.com](http://www.mcgaughys.com)

**READ THESE ENTIRE INSTRUCTIONS  
BEFORE STARTING ANYTHING**

- If you are the installer only, and not the owner of the vehicle, please make sure the owner of the vehicle gets these instructions. They contain very important information about the lift kit, maintenance, and warranty.
- Before moving forward with installation, please layout all parts from boxes and ensure everything is present. If any parts are missing, please contact McGaughy's Suspension immediately at 559-226-8196.
- If you alter the finish of any of the provided components, like zinc plating, chroming, or powder-coating, which can cause damage to the strength and structure of the metal, any warranties will be null and void.
- If any components are ground on or modified in any way, then no returns or exchanges will be accepted and any warranties will be null and void.
- NO welding is required to install any part of this lift kit. Do not weld any components.
- Over-sized tires and heavier wheels can cause premature wear on factory and aftermarket components like ball joints, bushings, tie-rod ends, wheel bearings, idler arms, drive-lines, etc.... You may need to replace / install new components sooner than factory recommendations based on the tires and wheels you choose. Please note that the heavier and wider wheels and tires combined with aggressive driving (off-road and on highways) will cause more wear on ALL moving parts, factory and aftermarket. Especially when vehicle is in 4wd or Auto-4wd / AWD modes.



**McGAUGHYS**  
S U S P E N S I O N P A R T S

559-226-8196  
4603 E. VINE AVE.  
FRESNO, CA 93725  
[www.mcgaughys.com](http://www.mcgaughys.com)

## WARRANTY INFORMATION

- McGaughy's warrants all **McGaughy's** products against manufacturer's defects in materials or workmanship for a period of **ONE-YEAR** from the date of original purchase. All McGaughy's spindles carry a **LIFETIME** warranty against manufacturer's defects.
- Warranty will not extend to any product or part there in, that has been improperly installed, abused, or neglected
- McGaughy's will not warranty any product(s) that were modified in any way. Check fit all products prior to custom painting, powder-coating, or any form of fabrication (sanding, drilling, painting, chroming, etc).
- There are **NO WARRANTIES** neither expressed nor implied for powder-coating on any McGaughy's products.
- McGaughy's is not responsible for damages and/or warranty of other vehicle parts (factory or aftermarket) related or non-related to the install of McGaughy's component(s).
- Warranty is limited to the repair or replacement (of McGaughy's product only), at McGaughy's discretion. And only after inspection of the defective part, once returned to McGaughy's with proof of purchase, date of purchase, and all shipping costs prepaid.
- Any cost of labor, freight, incidental or consequential damages are expressly excluded from warranty.

# FRONT INSTALLATION

Before starting this installation, we recommend loosening the factory front shocks with the vehicle on the ground. Once the vehicle is in the air, it is extremely difficult to access the upper shock nuts and they have a significant amount of tension on them. Loosen the top nut using a 21mm wrench, but DO NOT remove it all the way off. This holds up the front suspension. (pic 1)



With the parking brake set and wheel chocks behind the rear tires, use a jack to lift the front of the vehicle and place jack stands under the frame on each side. Remove the front wheels.



1. Using a 13mm wrench, unbolt the brake line brackets from the frame on both sides. Also unbolt the brake line bracket from the axle for extra maneuverability. (pic 2)

2. Support the front driveline with a suitable strap and remove the four front drive shaft flange bolts, using a 15mm socket. (pic 3)

3. Remove the driver side drag link to pitman arm nut using a 21mm socket. Use a tie-rod removal tool to avoid damaging the factory rod end. (pic 4)



4. Remove the pitman arm to steering box nut using a 46mm socket. (pic 5)

5. Using a pitman arm puller, remove the pitman arm from the steering box output shaft. (pic 6)

6. Remove the sway bar end link top nut on both sides using a 18mm socket. Separate the sway bar from the end links. (pic 7)



- 7. Remove the sway bar mounting bolts from the frame using a 15mm socket. (pic 8) And remove the sway bar.
- 8. Support the front axle and remove the front shock top nuts.
- 9. Remove the front shock lower mounting bolt using a 21mm socket. (pic 9) And remove the front shocks.
- 10. Lower the front axle until the front coil spring tension is released. Now remove the front coil springs. (pic 10)



- 11. Remove the track bar from the factory track bar bracket using a 27mm socket. (pic 11)
- 12. Use a cut-off wheel to remove the front bump stop mounts from the frame on both sides. DO NOT DESTROY. The factory bump stops and mounts will be reused. (pic 12)
- 13. Clean the remaining weld material from the frame using an abrasive disc or flap-wheel. (pic 13)
- 14. Clean the factory bump stop that was just removed as well. Be sure to paint both the frame and the mount.



- 15. Install the factory bump stop mount to the new extension brackets using the supplied 3/8" buttonhead allen bolts, washers, and locking nuts. (pic 14)
- 16. Install the factory bump stops back on the factory mounts. This may take some force. (pic 15)
- 17. Re-thread the bump stop mounting holes on the frame using the supplied 7/16" tap. Next, install the new bump stop assemblies onto the vehicle using the supplied 7/16" x 3/4" bolts. (pic 16)



**18.** Mount the new track bar relocation bracket using the factory hardware. Next, place something firm between the crossmember and the oil pan to prevent any damage. Now drill a brace hole using a 7/16" drill bit. (pic 17) Install using the supplied grade 8 7/16" x 1-1/2" bolts, washers, and locking nuts.

**19.** Drill out the top hole on the bracket using a 1/2" drill bit. Due to variances on the Ram frames, your vehicle may not require drilling. Install using the provided 1/2" x 1/2" bolt from the rear with washers and locking nut. (pic 18-19)



**20.** Remove the factory radius arms, using a 27mm socket on the upper axle bolt and a 24mm socket with a 27mm wrench on the lower axle bolt. (pic 20) Use a 27mm socket on the frame side to remove the radius arms. (pic 21)

**21.** Install the factory track bar into the new drop bracket using the supplied 18mm x 90mm bolt, washers, alignment cams, and locking nut. Torque to factory specs. Track bar alignment cams must be used in the 10" position. (pic 22) Place the cams on both side of the track bar bracket, so that the bolt can pass through with no obstruction.



**\*\*\* Before moving forward, Please refer to coil retainer instructions at the back.\*\*\***

**23.** Now install the new lift coils with lower tag aligned at the 9:00 position on the driver side and 3:00 position on the passenger side. The motor of the vehicle being the 12:00 position. The coils should be aligned with the sway bar end links when finished. Be sure the tighter coil windings face up and the open windings face down. (pic 24-25)

**NOTE: Be sure to install new shocks at this time. They are what keep the coils in place. Otherwise the coils will shift or fall out of place.**



**Driver Side**

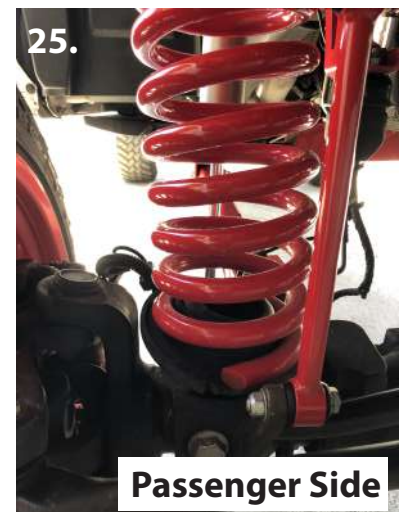

**Passenger Side**

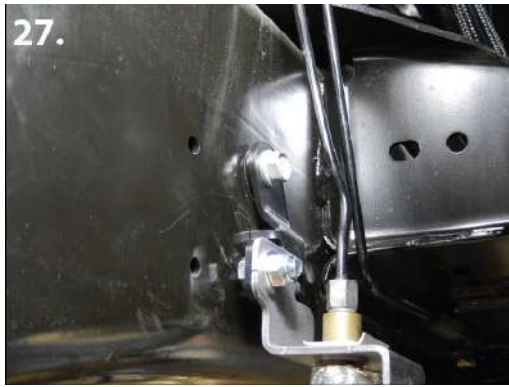

**24.** Install the supplied driver side brake line drop bracket on the frame using the factory hardware. Next, install the factory brake line bracket to the new drop down bracket using the supplied 5/15" x 3/4" hardware. (pic 26-27)

**25.** Now install the supplied passenger side brake line drop down bracket on the frame using the factory hardware. (pic 28) Then install the the factory brake line bracket to the new drop down bracket using the supplied 5/16" x 3/4" hardware. Be sure to re-attach the lower brake line brackets to the axle on both side, using a 13mm socket.



**25.** Install new drop pitman arm, DC602. Apply the supplied red thread locker to the factory pitman arm retention nut and tighten to factory specs. (pic 29)

**NOTE: Check and re-torque this nut after the first 500 miles fo driving.**

**26.** Loosen the drag link adjuster lock nuts. Turn the adjuster until the drag link is free.

**27.** Cut off the unthreaded portions of the end link, as shown. (pic 30-31)

**28.** Reinstall end back on the drag link. Insert the drag link end back into the pitman arm from the bottom, as shown. (pic 32) Tighten nut to factory specs.

**29.** Adjust the drag link to center teh front axle at ride height.



**30.** Install the provided sway bar drop brackets onto the factory sway bar. (pic 33-34)

**31.** Install new sway bar end link into new drop brackets on the sway bar and the factory lower mounts. (pic 35)

## RADIUS ARM INSTALLATION



1. Insert the frame spacer into the factory radius arm hole on the frame. (pic 1)

2. Position the radius arm drop down bracket and use the provided 5/8" x 5-1/2" bolt through the drop down bracket and frame spacer in the factory hole. Use a 18 x 130mm bolt through the center hole. (pic 2)



3. Using the drop down bracket as a guide, center punch where to drill the frame. Remove the drop down bracket and drill the marked spot on the frame to 43/64". (pic 3)

4. Insert the supplied rivet nut into the hole just drilled. Use a rivet tool to cinch down. You may need to tap it into the hole for it to fit properly. Tighten with IMPAC. (pic 4-6)



**5.** Use the provided 1/2" x 13 x 3/4" bolt into the rivet nut on the frame. (pic 7)

**6.** Insert spacer into center of radius arm drop down bracket and use provided 18 x 130mm bolt. (pic 8-9)

**7.** Now attach new radius arm into the drop down bracket using the provided 18 x 130mm bolt. Use the factory hardware on the axle side of new radius arm. (pic 10-11)



**8.** Now repeat steps 1 through 7 on the opposite side of the vehicle.

## REAR INSTALLATION



**1.** Support the rear axle and remove the parking brake cable retainer bracket nut. (pic 1)

**2.** Remove the top shock nut using a 18mm socket. Remove the bottom shock hardware using a 21mm socket and wrench. Now remove the shocks completely from vehicle. (pic 2-3) Repeat on the opposite side.



**3.** Remove the upper and lower sway bar end link hardware. Then remove the sway bar end link from vehicle. (pic 4-5) Repeat on the opposite side.

**4.** Remove the track bar to axle hardware.

**5.** Lower the rear axle until spring pressure has been safely released. Then remove the rear coils from the vehicle.



6.

**6.** Shown, are the rear 4-link frame mount sleeves. Use the narrow sleeves for the upper bolts and the wider sleeves for the lower bolts. (pic 6)



7.

**7.** These are the driver side rear 4-link mounts. The left bracket is the driver side outer and the right bracket is the driver side inner. (pic 7)



8.

**8.** Use the provided spacers and factory hardware to install the new 4-link brackets. (pic 8-9)

**9.** Before installing your factory upper arms into the new mounts. You will have to relieve a small section of the factory mount so that the new bolts will have clearance. Use provided 20mm x 130mm hardware. (pic 10)



9.



10.

**10.** Use the provided 20mm x 140mm bolt to install your factory lower arms into the new brackets.



11.

**11.** There is a small hole in the factory 4-link mount. This hole must be drilled out to 1/2". Once drilled out, use the provided shim to fill the void between the new bracket and the factory mount. Use the provided 1/2" x 1-1/2" bolt and tighten down. (pic 11-14)



12.

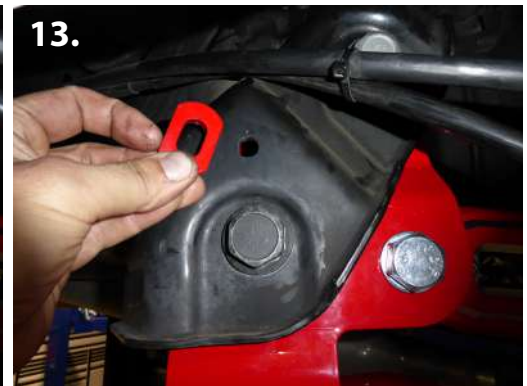

13.



14.



15.

12. Install the new rear 4-link drop support arm. First remove the bolt for the lower link bar. The new support arm slides over the outside of the new 4-link drop brackets. Reinstall the bolt through the support arm, both drop brackets, and the lower arm. (pic 15)

13. Repeat steps 8 through 12 on the opposite side of the vehicle. Once both sides are installed, you can now lift the support arm up against the bottom of the frame.

14. The 4-link drop support arm uses the provided rivet nuts, three per side. With the support arm in place against the frame, mark all three holes (per side) to be drilled. Then move the support arm out of the way and drill each hole to 11/16". Now install the three rivet nuts (per side). Once the rivet nuts are installed, you can now move the support arm back up in place and install using the provided 1/2" x 1-1/4" bolts.



16.



17.



18.

15. Install the passenger side rear lower coil mount. The mount can only fit one way. The "M" faces towards the back of the vehicle. Use the provided 3/8" x 1-1/4" hardware to install. (pic 16-17)

16. Now install the driver side rear lower coil mount. This mount also can only fit one way. The "M" face towards the back of the vehicle. Use the provided 3/8" x 1-1/4" hardware to install. (pic 18)

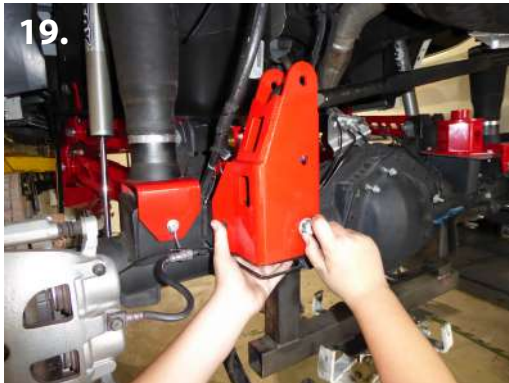

19.



20.



21.

17. The rear track bar bracket slips into the factory mount on the axle. Use the factory hardware to install, but **DO NOT FULLY TIGHTEN YET.** (pic 19)

18. Attach the rear track bar bracket brace from the coil spacer, using the provided 1/2" x 1-1/4" bolts, to the front side of the track bar bracket. (pic 20)

19. Use the provided 9/16" x 1-1/4" bolt through the one side of the track bar bracket to attach the brace to the bracket. **DO NOT FULLY TIGHTEN YET.** (pic 21)

20. Use the provided 9/16" x 3" bolt to install the factory track bar into the new track bar bracket. The bolt will pass through the track bar bracket, the track bar brace, and the track bar itself. **DO NOT FULLY TIGHTEN YET.**



**21.** Now install large rear track bar bracket brace. Remove the two bolts on the track bar bracket and reinstall with the large brace in place. (pic 22)

**22.** You can now tighten these two bolts. Be sure you are using a washer on the bolt head side. (pic 23)

**23.** Now tighten the bolt on the track bar bracket to the factory mount. The new track bar bracket should be sitting perpendicular to the axle. (pic 24)

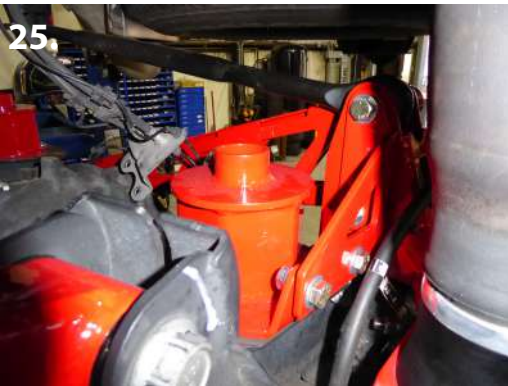

**24.** Tighten the two bolts going through the track bar brace and the coil spring mount. (pic 25)

**25.** You will now need to drill a 1/2" hole through the track bar bracket into the factory track bar mount. Once drilled, use the provided 1/2" x 1-1/4" bolt and tighten. (pic 26)

**26.** You will also need to drill a 1/2" hole for the large track bar brace underneath the passenger side coil bucket. Use the provided 1/2" x 1-1/4" bolt and tighten down through the bracket and coil bucket. (pic 27)



**27.** All hardware for the track bar bracket and braces should now be tightened. Finished, it should look like this. (pic 28-29)



30.



31.

**28.** Install the new lift coils, using the factory coil isolators on the top and bottom of the new coils. (pic 30)

**29.** Install the provided bushings and sleeves on the new sway bar end link. Be sure to grease the bushings before installing. Use the provided 1/2" x 2-3/4" bolts to install the new sway bar end link in the factory location. Tighten all four bolts. (pic 31)



32.



33.

**30.** Remove the factory bump stops using a 15mm socket. (pic 32)

**31.** Install the new rear bump stop extensions to the frame using the factory hardware. Now mount the factory bump stop to the new extension using the provided 3/8" x 1-1/4" hardware. (pic 33) Repeat this process on the opposite side of vehicle.

**NOTE: Be sure to install new shocks at this time. They are what keep the coils in place. Otherwise the coils will shift or fall out of place.**

**IMPORTANT: Double check all of the front and rear components, making sure everything has been properly torqued and tightened. This MUST be done before operating the vehicle. We recommend periodically check all of the front suspension and all lift kit components to be certain they are tight and in proper working order. Make sure vehicle is properly aligned before driving.**

**DODGE RAM RE-CLOCKING RING INSTRUCTIONS**  
**2014-22 2500 / 2013-22 3500 (for 6", 8", & 10")**



1. Place a jack under the transmission pan.

2. Using a 15mm socket, remove the three nuts that hold transmission mount to crossmember. (pic 1)

3. Use a 15mm socket to remove the bolts that hold the driveline to the rear differential. (pic 2)

4. Remove rear driveline from the transfer case. Place a rag under the output shaft so any light oil can be captured. (pic 3)



5. Remove the eight Christmas tree clips on the wire that routes along the transmission crossmember. (pic 4)

6. Remove the 4 bolts that hold the transmission crossmember to the frame, using a metric 24 socket and wrench. (pic 5)

7. Remove the transmission crossmember from the vehicle. (pic 6)



**8.** Remove the front drive line bolts from the transfer case using a 5/8" wrench. Remove the drive line from the vehicle using a 15mm socket. (pic 7)

**9.** Remove the rubber transmission mount from the transmission using a metric 15 socket. (pic 8)

**10.** Unplug the electrical connector on the transfer case. (pic 9)



**11.** Remove the 3 Christmas tree clamps that hold the wire to the transfer case. (pic 10) And disconnect the vent tube using pliers.

**12.** Using a metric 14 wrench, remove the six nuts that hold the transfer case to the transmission. (pic 11)

**13.** Using an inverted torque, remove the factory studs from the transmission case and discard. You can use pliers if you do not have an inverted torque. (pic 12)



**14.** Take the index ring and locate the position where the bolt pattern matches up to the transfer case. (pic 13)

**15.** Using the provided metric 10-1.5 x 25mm SNCS bolts, tighten the ring to the transfer case. Apply a small amount of loctite to the bolts and tighten using a 8mm allen wrench. (pic 14)

**16.** Install the supplied 3/8"-24 x 2" S.S. screw using a 3/16" allen wrench. Apply a small amount of loctite to each screw. Be sure to only screw in until it touches, then put a small amount of pressure to tighten. Torque to 5 ft/lbs.



NOTE: Picture 16 shows in the **recommended** 20 degree position. You will need to install the McGaughy's transmission crossmember in this position. Picture 17 shows the 10 degree position, which can run the factory crossmember with trimming.

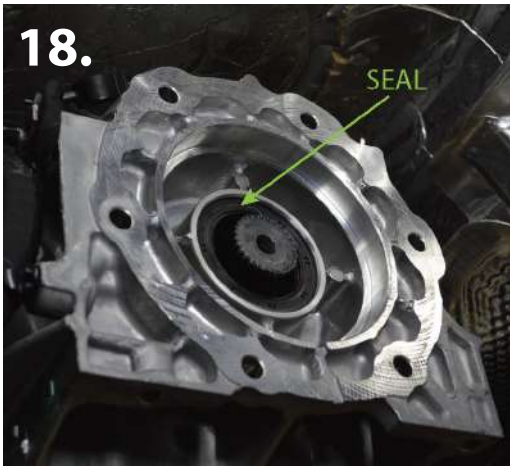

17. Remove the output shaft seal on the transmission and discard the factory seal. (pic 18)

18. Using a bearing race and seal driver, install the oil seal into the seal adaptor. (pic 19)

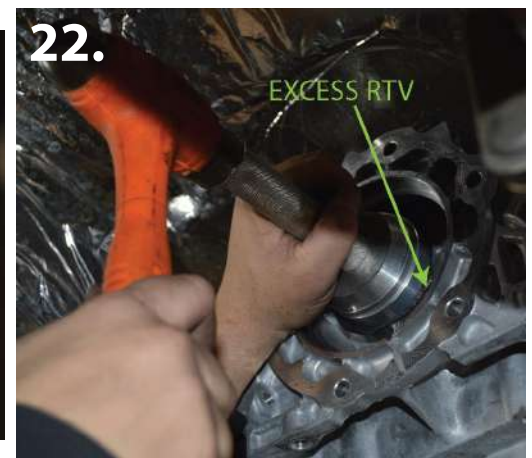

19. After the seal is installed, apply a small amount of RVT silicon to the seal adaptor. (pic 20) Also, apply a small amount of grease to the seal. (pic 21)

20. Tap the seal adaptor into the transmission where the factory seal was, using a bearing race and seal driver. Remove any excess RTV silicon. (pic 22)

**BE SURE TO LET SILICON SET FOR 24 HOURS BEFORE DRIVING**



**21.** Reinstall the transmission case to the transmission, using a 9/16" wrench and socket. Torque to factory specs. (pic 23)

**22.** Reconnect the vent tube to the vent port. Reinstall the electrical connector with the three Christmas tree clamps.

**23.** Reinstall the rubber transmission mount. Torque to factory specs. (pic 24)

**24.** Reinstall the front drive line. (pic 25)

**25.** If your kit came with a drive line spacer, install it now using the supplied 7/16" x 2" bolts. Use a small amount of loctite and a 5/8" wrench. (pic 26)

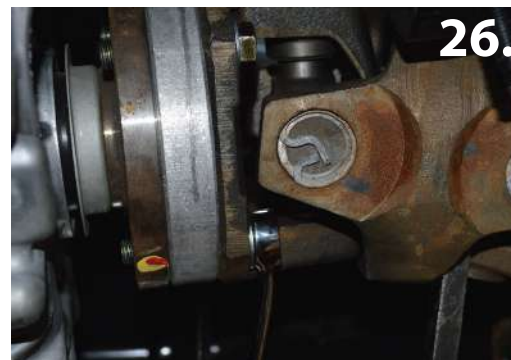

**26.** Install the McGaughey's crossmember with the large cut out on the driver side, using the factory hardware and a metric 24 wrench. (pic 27)

**27.** Reinstall the Christmas tree clamps using the holes provided in the crossmember.

**28.** Remove the clip that holds the electrical harness to the frame. (pic 28)

**29.** Make sure the wiring harness does not interfere with the drive line. (pic 29)

**30.** Now tighten the rubber transmission mount to the transmission crossmember using a metric 15 socket.

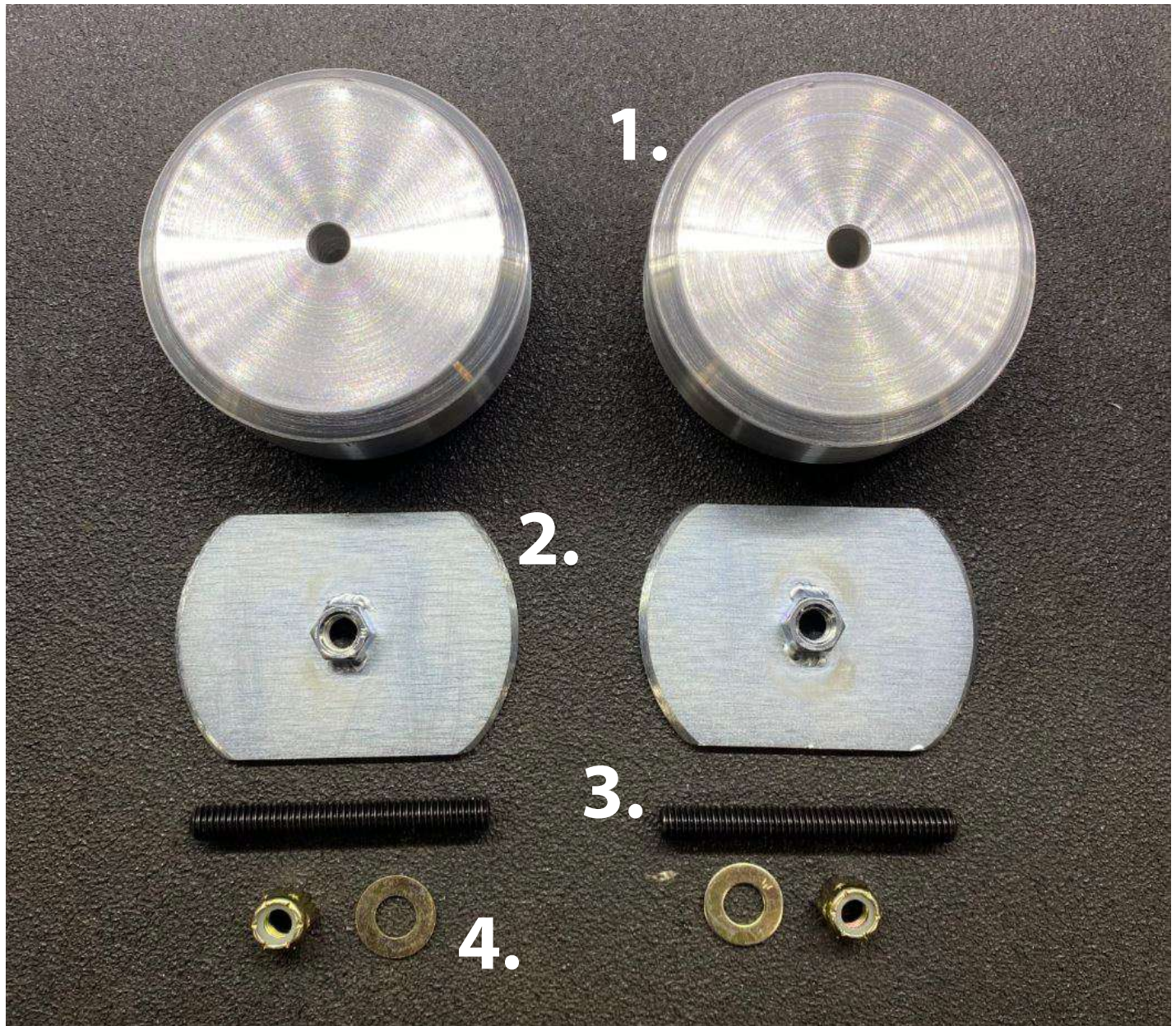

Kit Includes:

1. Coil Retainer Billet Pucks (2)
2. Retainer Backing Plate (2)
3. Retainer Bolt (2)
4. Hardware - Lock Nut (2) / Washer (2)



1. First apply loctite to the supplied retainer bolt. Then screw bolt into the retainer backing plate. Make sure bolt is flush with the top of the welded nut only. Do not screw the bolt past the backing plate.



2. Next, insert the backing plate with bolt into the opening on the factory upper coil mount.



3. With the backing plate installed, slide the supplied billet coil retainer puck in place. Make sure the billet puck slides into place in the opening on the mount. You may need to clean the edges of the opening with a file or sand paper, to be sure a nice tight fit. Then use the supplied washer and lock nut to install. Use an allen wrench and a 9/16" wrench to tighten to 20 ft/lbs.

4. Now re-install the factory coil isolator into the factory location.

5. Repeat these steps for the opposite side of the vehicle.