



Packaging Inspection Check-Off Form

Name(s): _____
Date box was packaged, inspected, weighed & verified to insure all parts were inside & correct: _____

27" x 16" x 9" = 125 lbs

BOX 1

- 19. U-Bolts (4)
- 2. Lift Blocks (2)
- 17. Differential Drop Brackets (2)
- 3. Lift Spindles (2)
- 12. Compression Strut Brackets (2)
- 15. Passenger Side Diff. Drop Brace

*items below are in white box

- 16. Rear Brake Line Bracket
- 18. Rear Emergency Brake Bracket
- 7. Compression Strut Bracket Nuts (2)
- 5. Front Brake Line Brackets (2)
- 8. Front Drive Line Spacer
- 20. Hardware Bag
- 21. Lower Ball Joints (2)
(MOOG# K500008)
- 14. Formed Steel Templates (2)

**2015-20 FORD F150 6.5" LIFT
PART# 57100**

45" x 14" x 14" = 135 lbs

BOX 2

- 9. Rear Crossmember
- 10. Front Crossmember
- 4. Skid Plate
- 6. Compression Struts (2)
- 1. Front Strut Spacers (2)
- 13. Rear Shocks (2)
- 11. Sway Bar Drop Brackets (2)

www.mcgaughys.com

NOTE: Spindles and u-bolts are shipped with protective coating on surface. This allows them to be delivered to you without rust. We recommend you clean and paint the parts before you install, to protect against any future rust. Remember, spindles and u-bolts are bare metal. And will rust without paint.



McGAUGHYS
S U S P E N S I O N P A R T S

559-226-8196
4603 E. VINE AVE.
FRESNO, CA 93725
www.mcgaughys.com

**READ THESE ENTIRE INSTRUCTIONS
BEFORE STARTING ANYTHING**

- If you are the installer only, and not the owner of the vehicle, please make sure the owner of the vehicle gets these instructions. They contain very important information about the lift kit, maintenance, and warranty.

-Before moving forward with installation, please layout all parts from boxes and ensure everything is present. If any parts are missing, please contact McGaughy's Suspension immediately at 559-226-8196.

-If you alter the finish of any of the provided components, like zinc plating, chroming, or powder-coating, which can cause damage to the strength and structure of the metal, any warranties will be null and void.

-If any components are ground on or modified in any way, then no returns or exchanges will be accepted and any warranties will be null and void.

-NO welding is required to install any part of this lift kit. Do not weld any components.

-Over-sized tires and heavier wheels can cause premature wear on factory and aftermarket components like ball joints, bushings, tie-rod ends, wheel bearings, idler arms, drive-lines, etc.... You may need to replace / install new components sooner than factory recommendations based on the tires and wheels you choose. Please note that the heavier and wider wheels and tires combined with aggressive driving (off-road and on highways) will cause more wear on ALL moving parts, factory and aftermarket. Especially when vehicle is in 4wd or Auto-4wd / AWD modes.



McGAUGHY'S
S U S P E N S I O N P A R T S

559-226-8196
4603 E. VINE AVE.
FRESNO, CA 93725
www.mcgaughys.com

WARRANTY INFORMATION

- McGaughy's warrants all **McGaughy's** products against manufacturer's defects in materials or workmanship for a period of **ONE-YEAR** from the date of original purchase. All McGaughy's spindles carry a **LIFETIME** warranty against manufacturer's defects.
- Warranty will not extend to any product or part there in, that has been improperly installed, abused, or neglected
- McGaughy's will not warranty any product(s) that were modified in any way. Check fit all products prior to custom painting, powder-coating, or any form of fabrication (sanding, drilling, painting, chroming, etc).
- There are **NO WARRANTIES** neither expressed nor implied for powder-coating on any McGaughy's products.
- McGaughy's is not responsible for damages and/or warranty of other vehicle parts (factory or aftermarket) related or non-related to the install of McGaughy's component(s).
- Warranty is limited to the repair or replacement (of McGaughy's product only), at McGaughy's discretion. And only after inspection of the defective part, once returned to McGaughy's with proof of purchase, date of purchase, and all shipping costs prepaid.
- Any cost of labor, freight, incidental or consequential damages are expressly excluded from warranty.



McGAUGHY'S
S U S P E N S I O N P A R T S

559-226-8196
www.mcgaughys.com

2015-20 FORD F150 6.5" LIFT PART# 57100

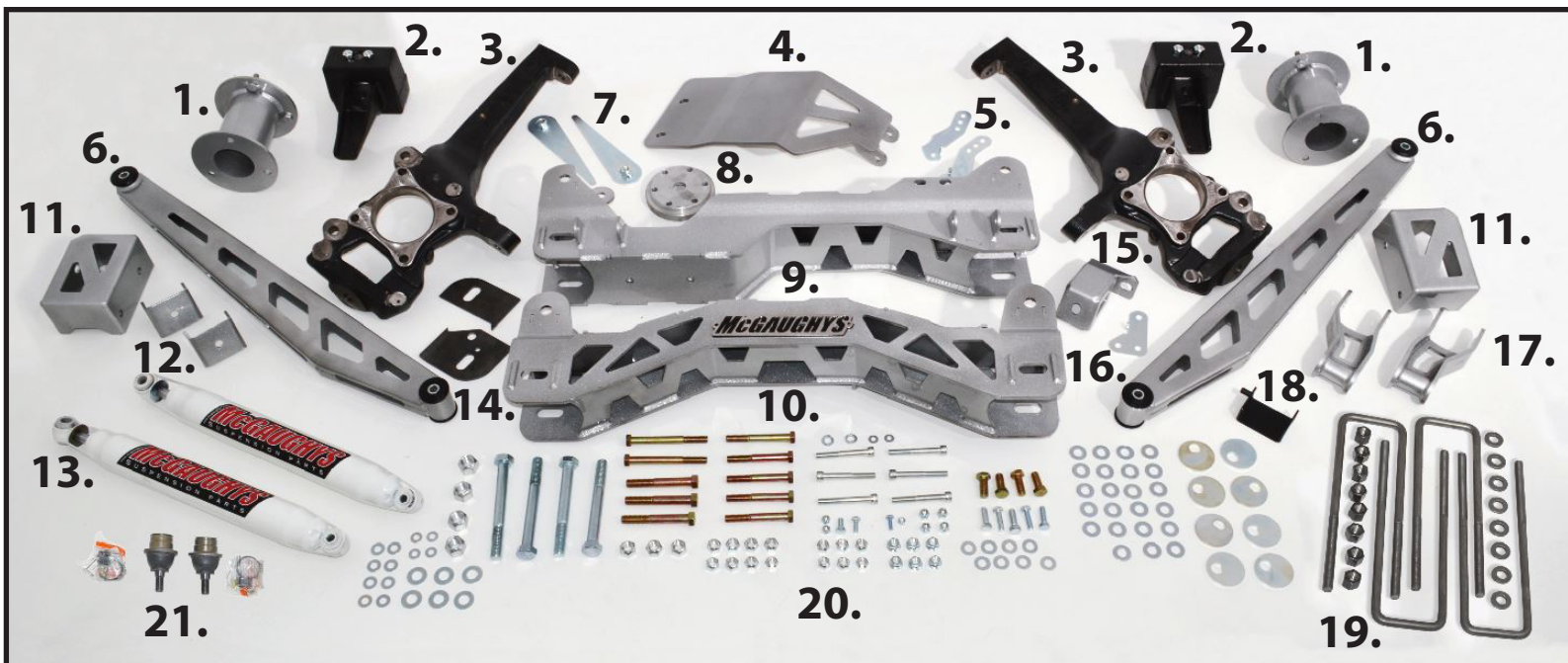

1. Front Strut Spacers
2. Rear Lift Blocks
3. Lift Spindles
4. Skid Plate
5. Front Brake Line Brackets
6. Compression Struts
7. Compression Strut Bracket Nuts
8. Front Drive Line Spacer
9. Rear Crossmember
10. Front Crossmember
11. Sway Bar Drop Brackets
12. Compression Strut Brackets
13. Rear Shocks
14. Steel Templates
15. Passenger Side Diff Drop Brace
16. Rear Brake Line Bracket
17. Diff Drop Brackets
18. Emergency Brake Line Bracket
19. U-Bolts
20. Hardware Packs
21. Lower Ball Joints (MOOG# K500008)

FRONT INSTALLATION

Always use the proper tools and consult the factory service manual for torque values and procedures. With the vehicle turned off and the parking brake set, secure the rear wheels/tires with wheel chocks. Use a jack and lift the front of the vehicle. Place jack stands under the frame on both side of the vehicle. Remove the front wheels.

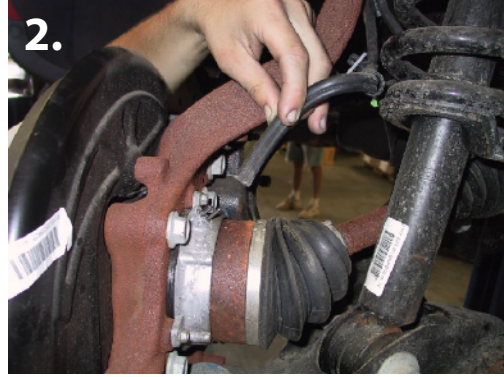

1. Disassemble the front components. Start by unbolting the sway bar end links and removing the sway bar. Remove the factory brake line bracket and rubber hose. (pic 1) Next, unbolt the caliper and secure it out of the way. Do not just let it hang. Remove rotors, dust cap, and CV hut from hub.
2. Disconnect the anti-lock brake sensor and the vacuum line from the factory hub. (pic 2) Remove the tie rod nut and tie rods ends from the spindle. Remove the upper and lower ball joints. (pic 3) Disconnect the CV axles from the spindles and remove the spindles from the truck.



3. Disassemble the factory spindle bearings. (pic 4)
4. Remove the factory struts, three bolts on top and one on bottom mount. (pic 5)
5. Remove the lower a-arms from vehicle. Mark the front driveline location and disconnect from diff.

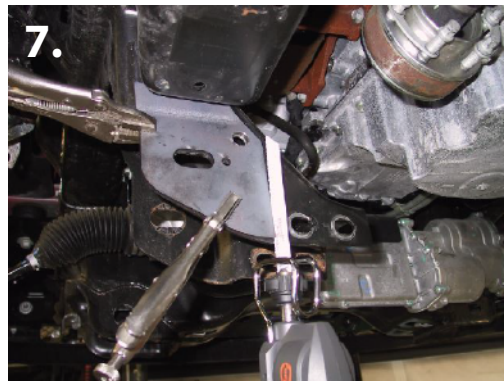

6. Use provided templates to cut on driverside for differential to drop. Place large template on back side of the rear lower a-arm mount. Line up with factory lower a-arm slot. Make sure factory slot and hole are lined up. Clamp to hold in place. Drill the top hole to 9/16". (pic 6)
7. With the hole drilled, you can now cut along the template as a guide. (pic 7)
8. Use the smaller template on the front side of the same lower a-arm mount. Line up the slotted holes and clamp in place. Cut along the template as a guide. (pic 8)
9. Now fully cut and remove that piece of the frame.

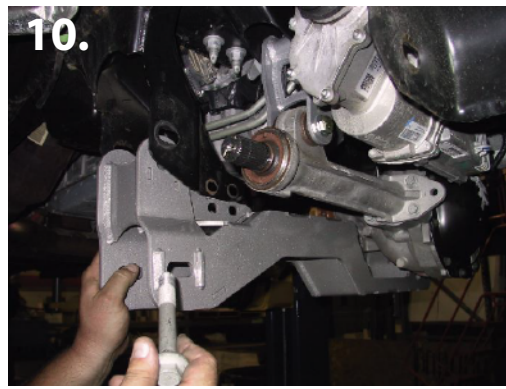
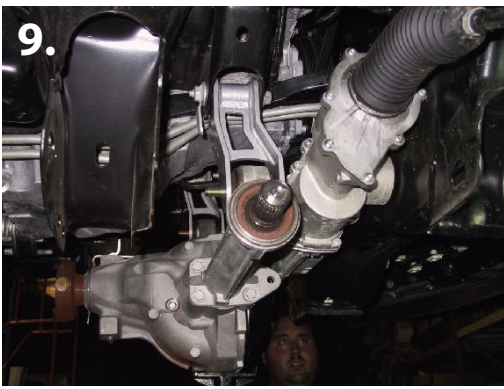

10. Install the provided diff drop brackets onto the frame in the factory location, using the factory bolts on both sides. Bolt heads should be towards the front of the truck. Do not tighten yet.

11. Now install the differential to the new diff drop brackets, using

the provided 9/16" x 4" hardware. Bolt heads should be towards the front of the truck also. Do not tighten yet. (pic 9) You can now reconnect the differential breather line you removed earlier.

12. Install the new rear crossmember. Install the driver side first, then the passenger side. Use the factory hardware and install into the factory lower a-arm pockets. (pic 10) Do not tighten yet.

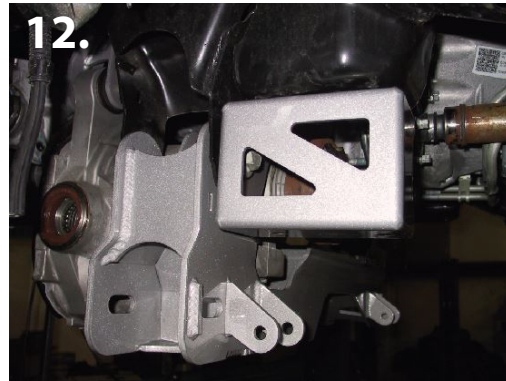
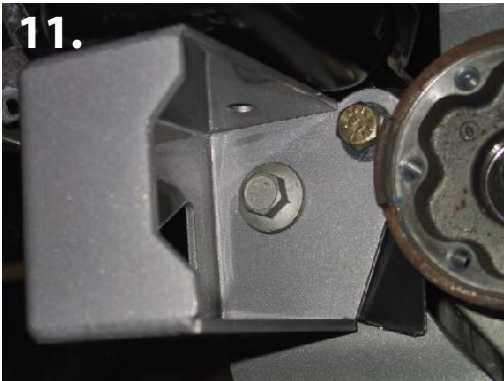

13. Install driver side sway bar drop bracket using the factory bolt with bolt head at the rear. Bolt will go through sway bar drop bracket and rear cross-member. Use the provided 9/16" x 4" bolt for the hole you drilled out on the frame earlier. Use the provided 3/8" x 1-1/4" bolts with nylock nuts on upper holes. (pic 11-12)

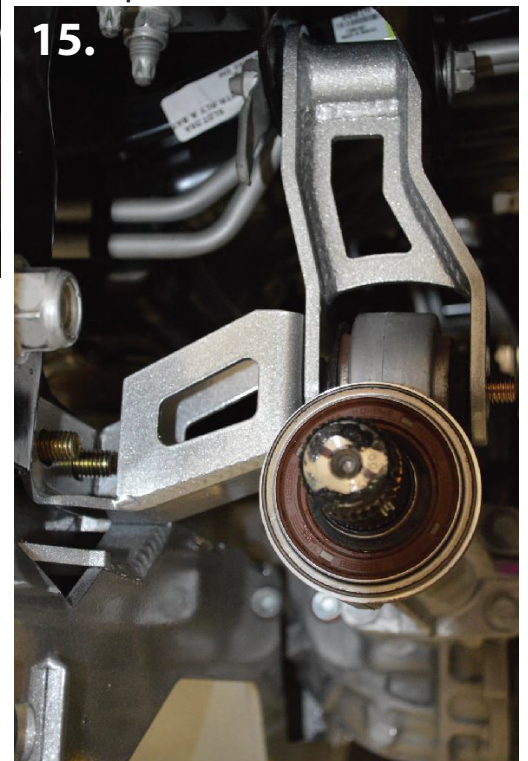
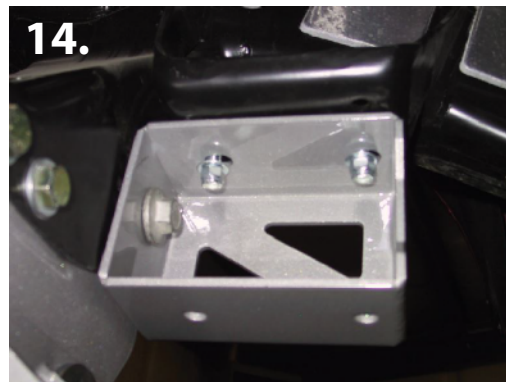
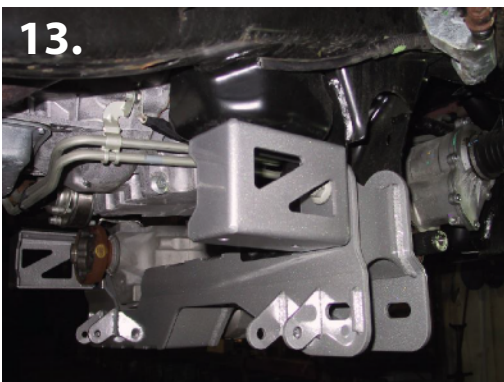

14. Install the passenger side sway bar drop bracket using the factory hardware. Use the provided 3/8" x 1-1/4" bolts with nylock nuts on upper holes. (pic 13-14)

15. Next, install the front crossmember into the factory lower a-arm pockets using the factory hardware. "McGaughys" name badge faces front of the truck.

16. Install the passenger side diff drop brace. This brace installs between the new diff drop bracket (uses same bolt) and the rear crossmember. Use the provided 1/2" x 4-3/4" bolts. (pic 15) You can now tighten ALL the diff drop bolts on both brackets and the brace.

17. Install the provided strut spacers onto the top of the factory struts. Use the factory hardware to bolt on. Next, install the full strut assembly onto the vehicle in the factory location. Use the provided 7/16" top lock nuts to bolt down. (pic 16)

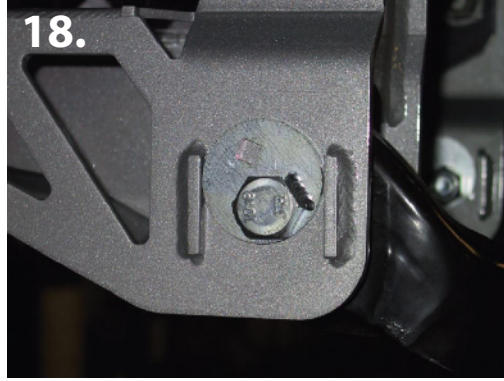
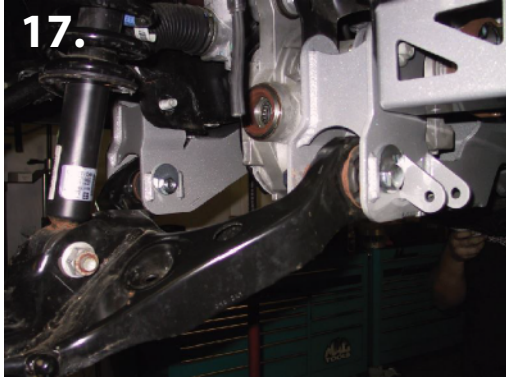

18. Install the factory lower a-arms into the front and rear crossmembers. Use the provided 18mm bolts. The longer bolt goes in the front crossmember with the bolt head facing the front of the truck. (pic 17-18) The shorter of the 18mm bolts are used on the rear crossmember. Bolt head will

face the rear of the truck. Make sure each head and nut has an alignment cam installed. The alignment cams will fit inside the two welded rectangular bars on the crossmembers. You can now go through and tighten all the hardware for both crossmembers. Do not forget to tighten all sway bar drop hardware too.

19. Install the factory sway bar onto the new sway bar drop brackets. Use the factory hardware.

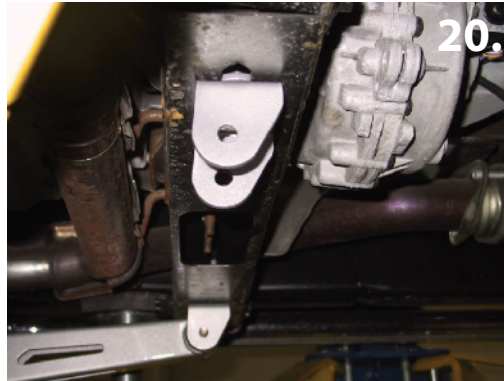

20. Install the provided front skid plate. The skid plate will bolt to the back side of the front crossmember using the provided 1/2" x 4" bolt and lock nut. The flat side of skid plate will bolt onto the rear crossmember using the provided 1/2" x 1-1/4" bolts. These bolts will screw into the threaded holes on bottom of crossmember. (pic 19)

21. Install the compression strut brackets onto the factory transmission crossmember. Straight side of bracket will be towards the front of truck. Insert the provided nut brackets into the crossmember and bolt on using the provided 1/2" x 1-1/4" bolt. (pic 20) Do not tighten yet.

22. Now bolt the compression struts into the vehicle. Bolt onto the rear crossmember first, using the provided 1/2" x 3-3/4" bolts and lock nuts. The swing the compression strut up and into the brackets you bolted onto the transmission crossmember. Bolt in place using the 1/2" x 3-3/4" hardware. Now tighten all the hardware for the compression struts and brackets. (pic 21)



22.



Grease Relief Passage

23.

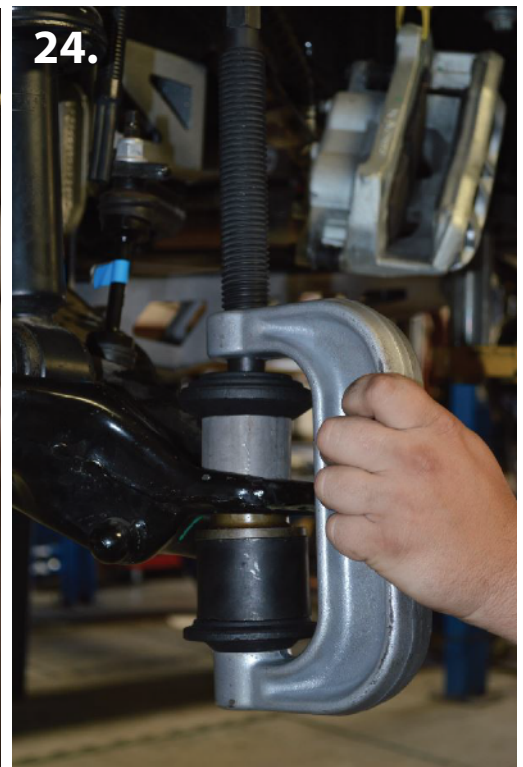

24.



25.

23. Remove the factory lower ball joints from the factory lower a-arms, by removing the factory retaining clip on top and pressing ball joint out towards the ground. (pic 22)

24. Install new provided lower ball joints into factory lower a-arms. Make sure grease relief passage is inwards, then press in ball joint from the bottom until it is flush with the bottom side. (pic 23-24)

25. Install snap ring and grease zerk that came with new ball joint. Make sure you grease the ball joint before use. It does not come pre-greased. (pic 25) **Replacement ball joint: MOOG# K500008**



26.

26. Install the factory hub onto the new lift spindles. Be sure to use the provided loctite on the hub bearing bolts.

27. Reinstall the CV axles into the factory location on the front differential.

28. Now install the new lift spindles onto the truck by inserting the lower ball joint and hand tightening the nut. Next, install the CV axle through the vacuum actuator and into the factory bearing bolted to the new spindles.

29. Install the upper ball joint into the spindle. Torque upper and lower ball joints to factory specs

30. Now torque CV nut to factory specs. (pic 26)

31. You can now reinstall the factory dust shield onto the new spindles using the factory hardware.

32. Reinstall the factory rotor and caliper using factory hardware.



27.



28.

33. Install the brake line extension brackets. Both new brackets have a tab to locate them onto the frame. Bolt them onto the frame using the factory hardware. Bolt the brake line onto the new bracket using the provided 5/16" x 3/4" hardware. (pic 27-28)

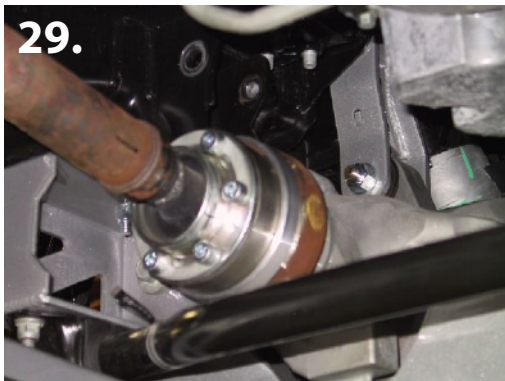

29.

34. Be sure to run the factory ABS line along the factory vacuum line and zip-tie them together.
35. Make sure you turn the wheel fully in both directions, to verify that there is no rubbing or any lines are being other stretched.
36. Reinstall the factory tie rod ends onto the new spindles.
37. Reconnect the front driveline using the provided front drive-line spacer and bolts. (pic 29)
38. Be sure to go over all front components, making sure everything is tight and nothing is rubbing.

REAR INSTALLATION

With the vehicle turned off and the parking brake set, secure the front wheels/tires with wheel chocks. Use a jack and lift the rear of the vehicle. Place jack stands under the frame on both side of the vehicle. Remove the rear wheels.



30.

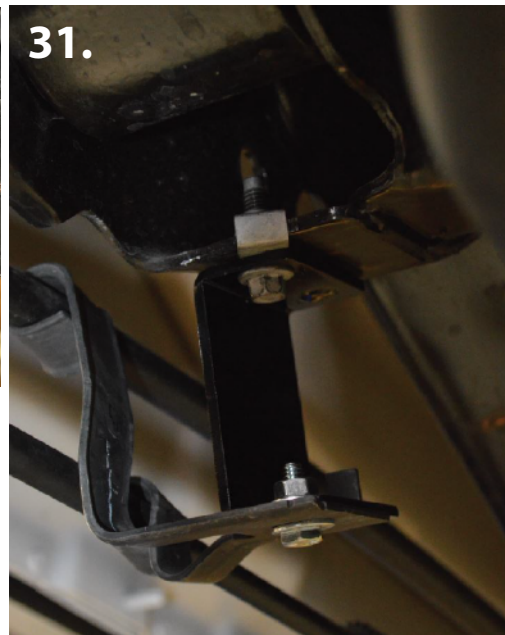

31.

39. Disconnect and remove the factory rear shocks.
40. Install new driver side brake line extension bracket using the factory hardware. Install the factory brake line bracket onto the new extension bracket using the provided 5/16" x 3/4" hardware. (pic 30)

41. Install the new provided emergency brake line extension bracket on driver side. Insert the spacer with dowel facing upwards. Bolt new bracket on with factory hardware and the provided 1/4"-20 x 1" hardware. (pic 31)

***** NOTE: If your vehicle is equipped with the electric brake system, then you will NOT need to use this bracket.**



42. With the rear end supported, loosen and remove the factory u-bolts. Insert the provided lift blocks onto the rear end between the leaf springs and rear axle. The ear on the lift blocks points inwards. (pic 32) Torque all four u-bolts to factory specs.

43. Install new rear shocks into the factory location using the factory hardware. Make sure body of shock is towards the ground. (pic 33)

*** Double check all of the front and rear fasteners and components, making sure everything has been torqued to the proper specifications. This MUST be done before operating the vehicle.**

*** Vehicle MUST be properly aligned before driving.**

*** After 500 miles, be sure to go over all of the front and rear suspension and lift components to make sure nothing has come loose and everything is still tight.**

*** We recommend periodically checking all of the front and rear suspension and lift components to be sure they are tight and in proper working order.**